

TWEETER

27TAF/G

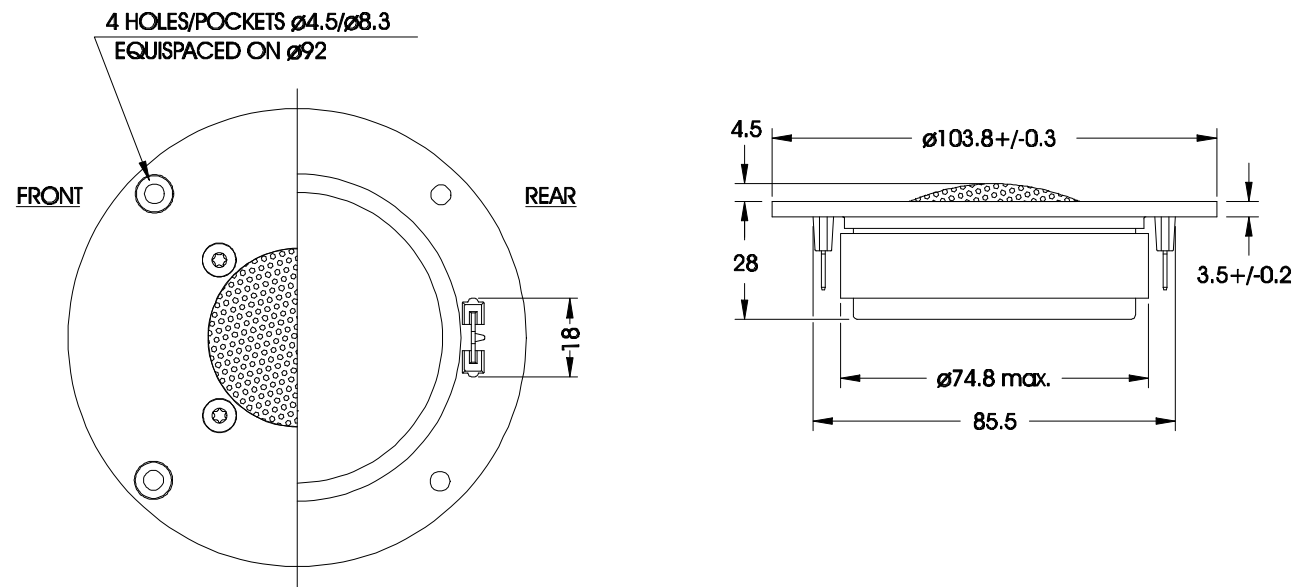

27mm High Definition aluminium/magnesium alloy dome tweeter with a wide, soft fabric surround made from SONOTEX. The dome and surround materials give high consistency and excellent stability against variations in air humidity and temperature. The diaphragm is protected by a highly perforated hexagrid carrying an acoustic lens which tailors the high frequency roll off characteristic. The voice coil is wound on an aluminium voice coil former with adequate ventilating holes to eliminate noise from internal air flow. The voice coil is immersed in low viscosity magnetic fluid, for high power handling capacity and simplified crossover design. An optimally damped cavity in the pole piece controls and slightly lowers the fundamental resonance. The chassis is precision moulded from glass fibre reinforced plastic, and its front design offers optimum radiation conditions.

NOTES

Response curve recorded in anechoic chamber (Free-field, 4 pi radiation) with 0.5m microphone distance. The loudspeaker is mounted in a 0.6m by 0.8m baffle.

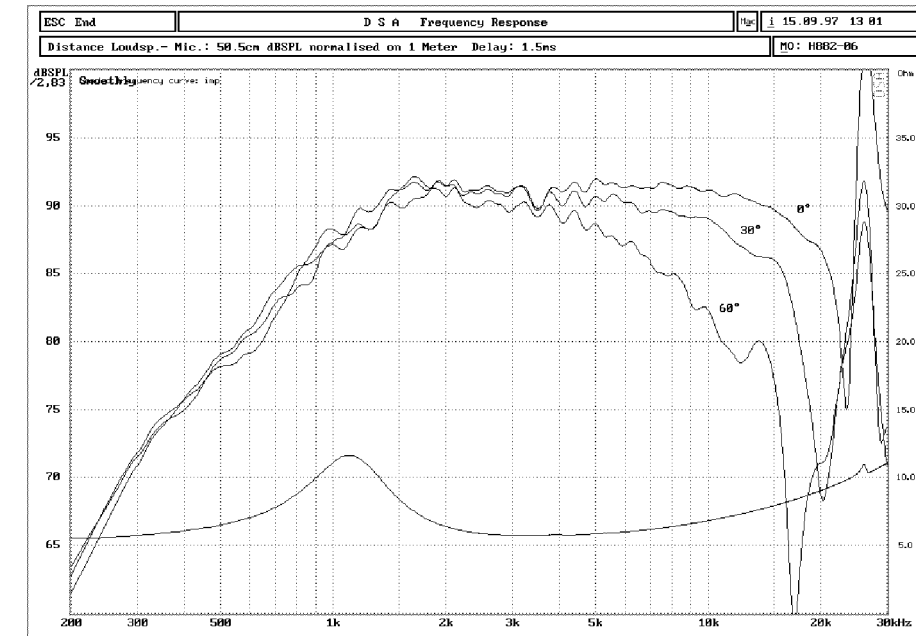

Cumulative spectral decay

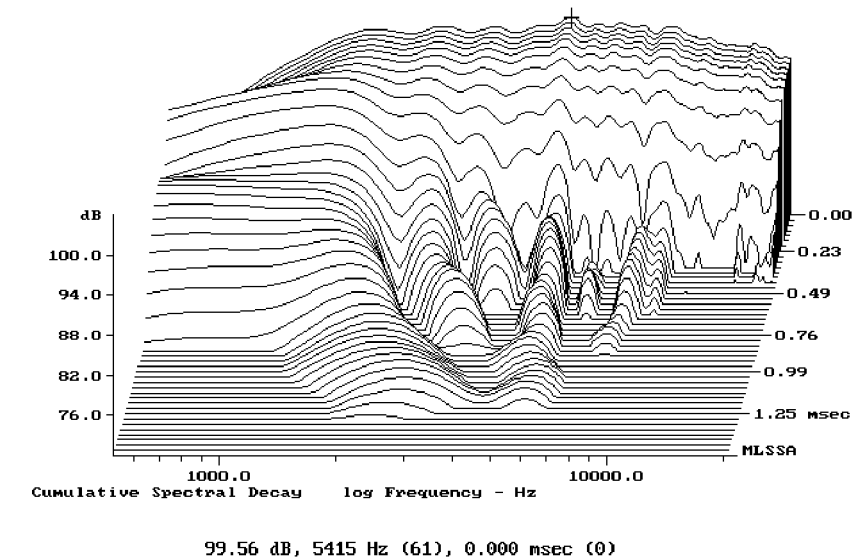

NOMINAL IMPEDANCE	6 Ohms	VOICE COIL RESISTANCE	4.8 Ohms
RECOMMENDED FREQUENCY RANGE	3000-25000 Hz	VOICE COIL INDUCTANCE (EQUIVALENT)	0.05 mH
SHORT TERM MAXIMUM POWER*	240 W	VOICE COIL DIAMETER	26 mm
LONG TERM MAXIMUM POWER*	100 W	VOICE COIL HEIGHT	1.5 mm
CHARACTERISTIC SENSITIVITY (1W , 1m)	91 dB SPL	MOVING MASS	0.32 g
OPERATING POWER (96 dB SPL , 1 m)	3.2 W	EFFECTIVE PISTON AREA	7.6 sq.cm
		LINEAR COIL TRAVEL (p-p)	0.5 mm
AIR GAP HEIGHT	2.0 mm	FREE AIR RESONANCE	1200 Hz
MAGNETIC GAP FLUX DENSITY	1.8 T		
FORCE FACTOR	3.5 N/A		
MAGNET WEIGHT	0.25 Kg		
TOTAL WEIGHT	0.50 Kg		

* IEC 268-5, VIA HIGH PASS BUTTERWORTH FILTER: 3500 Hz 12 dB/oct.