

## WOOFER

## P17RE

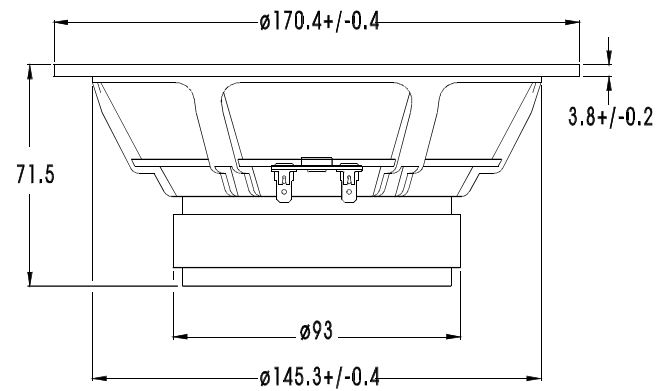
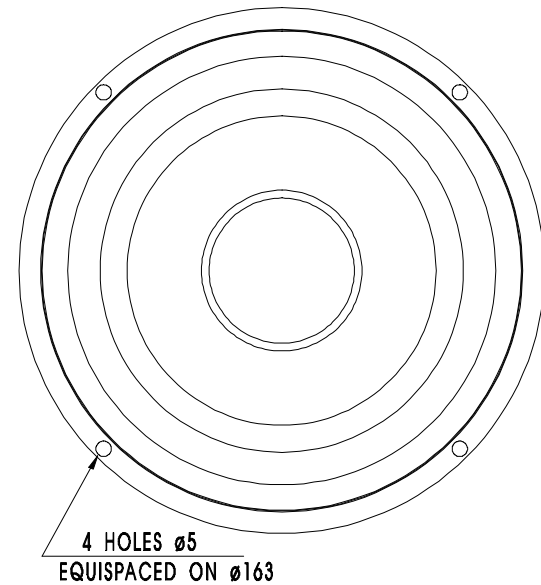

P17RE is a 6,5" High Fidelity woofer with an injection moulded metal chassis. A polypropylene based cone, a soft PVC dust cap and a high loss rubber surround are carefully matched to each other, resulting in an outstandingly smooth frequency response. The unit has a high power handling capacity due to its relatively large voice coil diameter. The magnet system has a T-shaped cross section of the pole piece for low modulation distortion.

### NOTES

---



---



---



---

Response curve recorded in anechoic chamber (Free-field, 4 pi radiation) with 0.5m microphone distance. The loudspeaker is mounted in a closed box of 12 l net volume.

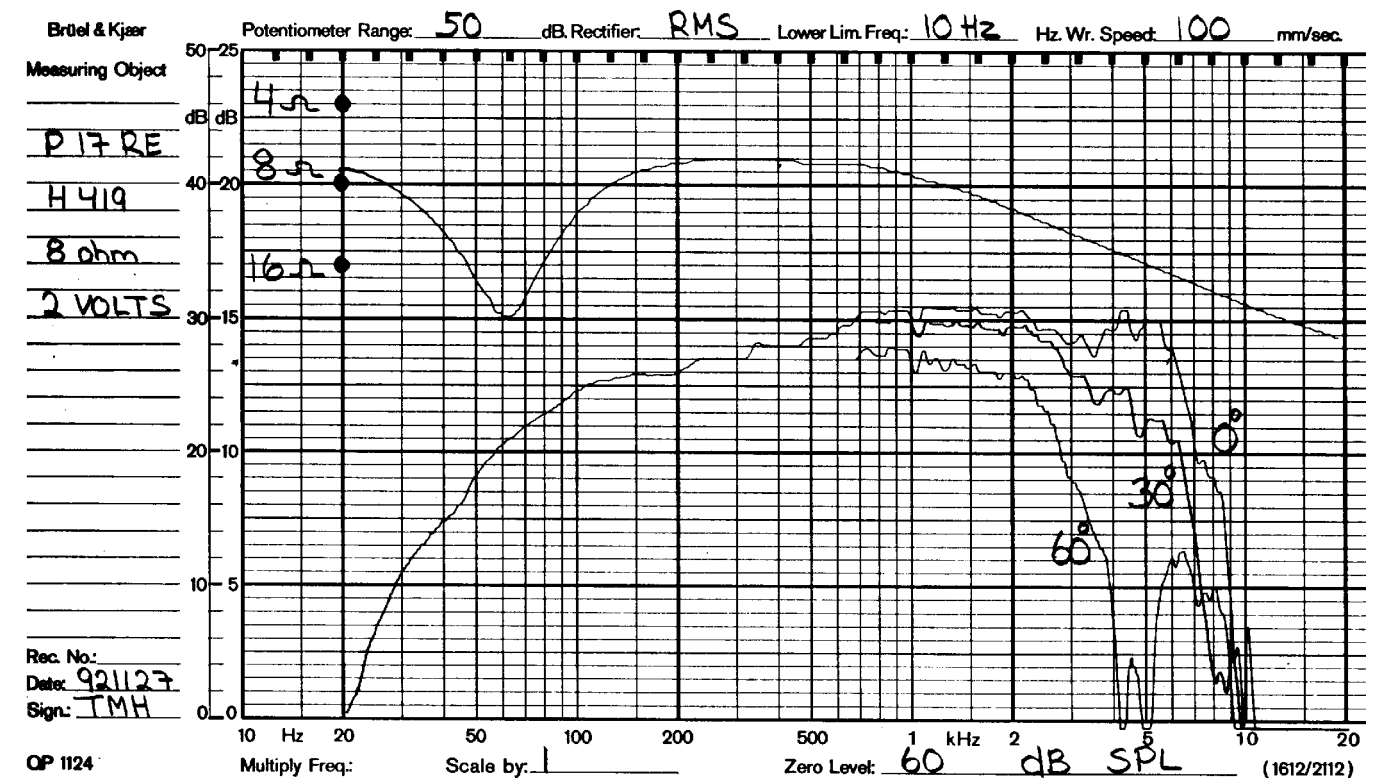

NOMINAL IMPEDANCE	8 Ohms	VOICE COIL RESISTANCE	6.1 Ohms
RECOMMENDED FREQUENCY RANGE	40-3000 Hz	VOICE COIL INDUCTANCE (EQUIVALENT)	0.6 mH
SHORT TERM MAXIMUM POWER *	250 W	FORCE FACTOR	7.0 N/A
LONG TERM MAXIMUM POWER *	80 W	FREE AIR RESONANCE	34 Hz
CHARACTERISTIC SENSITIVITY (1W,1m)	87.5 dB SPL	MOVING MASS	16 g
OPERATING POWER (96 dB SPL ,1 m)	7.0 W	AIR LOAD MASS IN IEC BAFFLE	1.0 g
		SUSPENSION COMPLIANCE	1.4 mm/N
VOICE COIL DIAMETER	39 mm	SUSPENSION MECHANICAL RESISTANCE	3.0 Ns/m
VOICE COIL HEIGHT	12 mm	EFFECTIVE PISTON AREA	130 sq.cm
AIR GAP HEIGHT	6.0 mm		
LINEAR COIL TRAVEL (p-p)	6.0 mm		
MAXIMUM COIL TRAVEL (p-p)	19 mm	VAS	30.5 Litres
MAGNETIC GAP FLUX DENSITY	0.85 T	QMS	1.21
MAGNET WEIGHT	0.42 Kg	QES	0.45
TOTAL WEIGHT	1.41 Kg	QTS	0.33

\* = IEC 268-5