

WOOFER

L15RLY/P

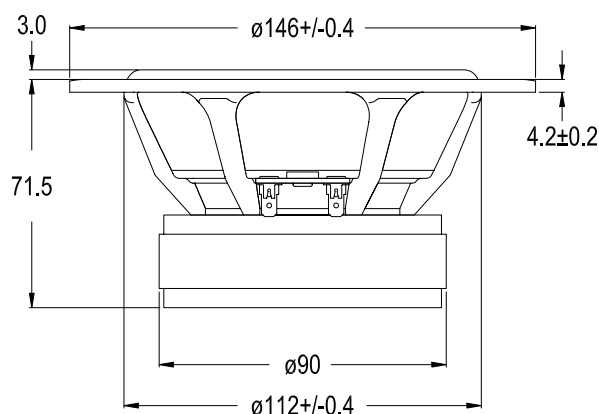
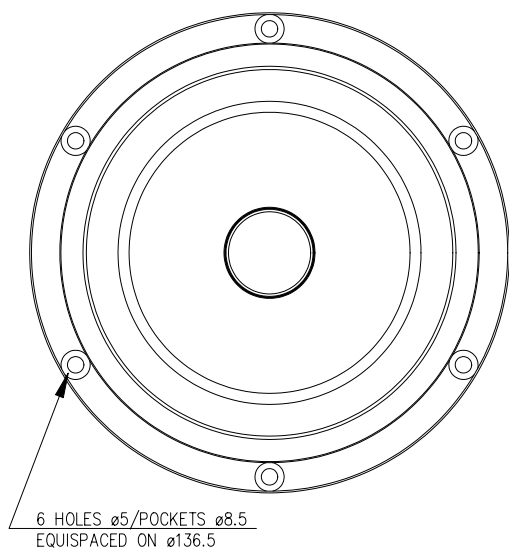

The L15RLY/P is a 15 cm (5") cone driver, developed for use as a long throw high fidelity woofer or woofer/midrange unit.

The stiff, yet light aluminium cone and the low loss rubber surround show no sign of the familiar 500-1500 Hz cone edge resonance and distortion associated with soft cones. On the other hand, the cone break up modes at higher frequencies call for special attention in the crossover design work.

The large magnet system, together with the very long, and light weight copper clad aluminium voice coil allow for extreme coil excursion with low distortion and good transient response.

The extremely stiff and stable injection moulded metal basket, keeps the critical components in perfect alignment. Large windows in the basket both above and below the spider reduce sound reflection, air flow noise and cavity resonance to a minimum.

NOTES

The frequency responses below show measured free field sound pressure in 0, 30, and 60 degrees angle using a standard baffle (IEC 268-5). Input 2.83 Volts RMS, microphone distance 1m. The dotted line is a calculated response for an infinite baffle based on the parameters given for this specific driver below. The impedance is measured in free air without baffle.

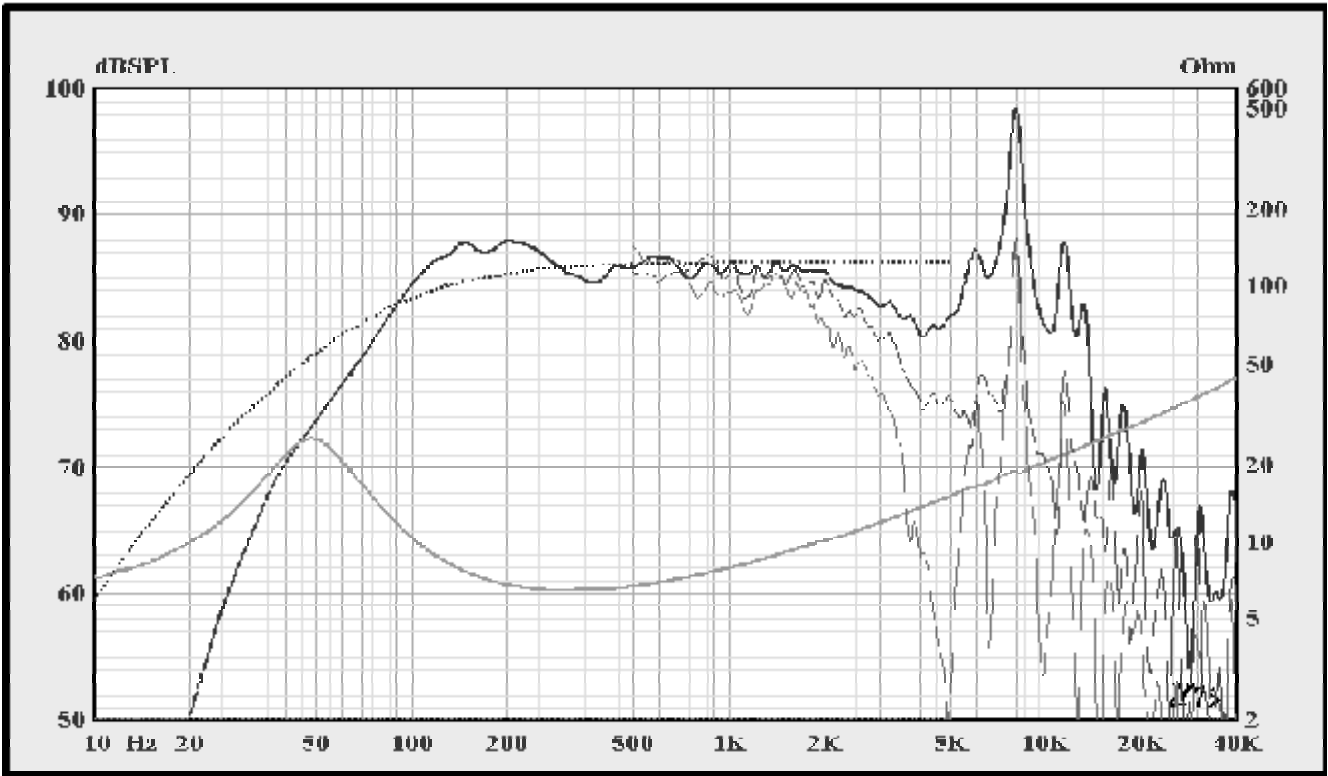

NOMINAL IMPEDANCE	8 Ohms	VOICE COIL RESISTANCE	5.9 Ohms
RECOMMENDED FREQUENCY RANGE	45-3000 Hz	VOICE COIL INDUCTANCE (EQUIVALENT)	0.61 mH
SHORT TERM MAXIMUM POWER *	200 W	FORCE FACTOR	5.2 N/A
LONG TERM MAXIMUM POWER *	80 W	FREE AIR RESONANCE	46 Hz
CHARACTERISTIC SENSITIVITY (2.83V, 1m)	86 dB SPL	MOVING MASS	7.3 g
		AIR LOAD MASS IN IEC BAFFLE	0.38 g
VOICE COIL DIAMETER	26 mm	SUSPENSION COMPLIANCE	1.6 mm/N
VOICE COIL HEIGHT	16 mm	SUSPENSION MECHANICAL RESISTANCE	1.5 Ns/m
AIR GAP HEIGHT	6 mm	EFFECTIVE PISTON AREA	75 sq.cm
LINEAR COIL TRAVEL (p-p)	10 mm		
MAXIMUM COIL TRAVEL (p-p)	20 mm	VAS	12 Litres
MAGNETIC GAP FLUX DENSITY	1.25 T	QMS	1.51
MAGNET WEIGHT	0.42 Kg	QES	0.48
TOTAL WEIGHT	1,28 Kg	QTS	0.37

* = IEC 268-5